

1/2"X45.0 MM SLIDING WINDOWS

2023-24

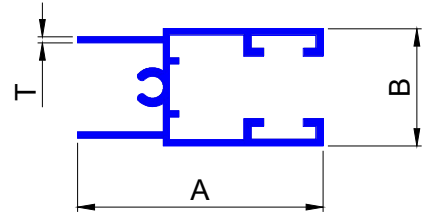
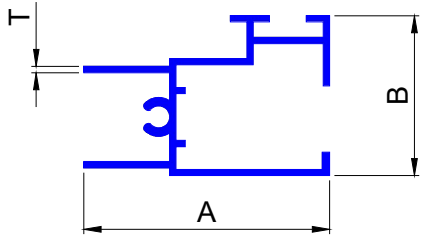

SEC.NO.	A	B	T	WT.Kg/mtr.
2904	31.00	20.50	0.70	0.220
2905	31.00	20.50	0.75	0.229
2907	31.00	20.50	1.05	0.287

SEC.NO.	A	B	T	WT.Kg/mtr.
2908	31.50	15.00	0.60	0.185
2911	31.50	15.00	1.10	0.287

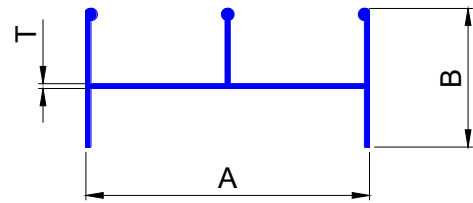
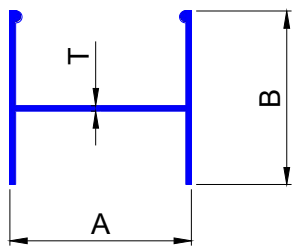

SEC.NO.	A	B	T	WT.Kg/mtr.
2915	23.00	22.00	0.60	0.114
2916	23.00	22.00	0.70	0.128

SEC.NO.	A	B	T	WT.Kg/mtr.
2924	45.00	22.00	0.80	0.226

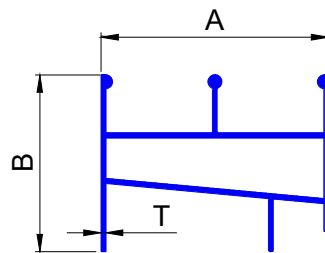

SEC.NO.	A	B	T	WT.Kg/mtr.
2928	45.00	35.00	1.00	0.458

SLIDING WINDOWS

2023-24

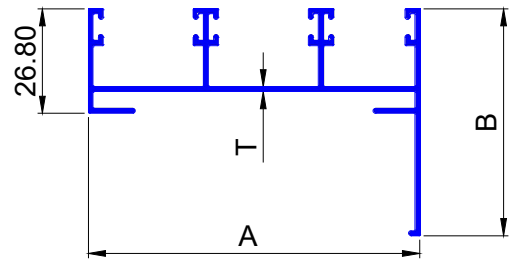
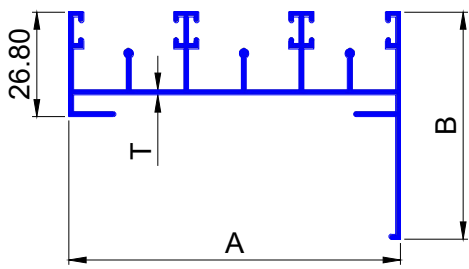

SEC.NO.	A	B	T	WT.Kg/mtr.
2932	85.00	58.20	1.20	1.023

SEC.NO.	A	B	T	WT.Kg/mtr.
2933	85.00	58.20	1.20	0.906

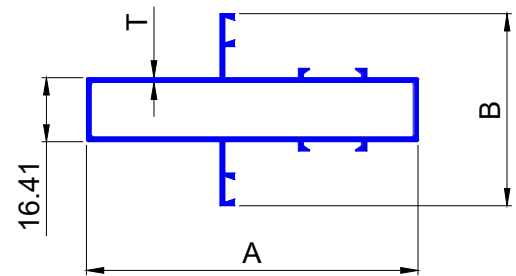
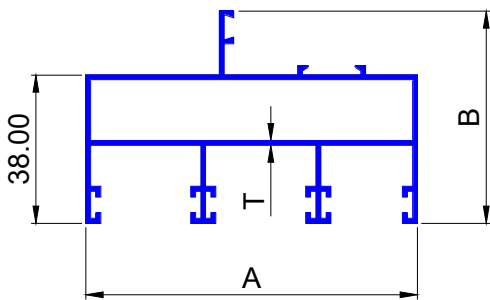

SEC.NO.	A	B	T	WT.Kg/mtr.
2935	85.00	54.40	1.20	1.164

SEC.NO.	A	B	T	WT.Kg/mtr.
2936	85.04	49.22	1.20	0.827

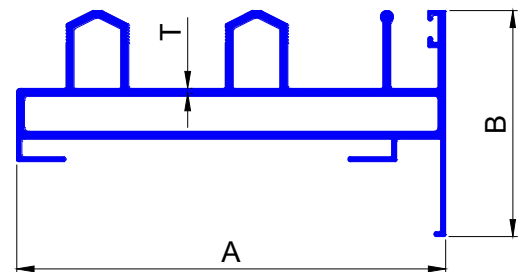
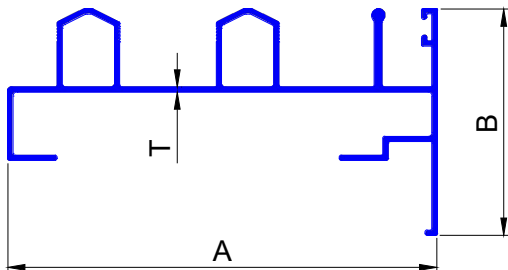

SEC.NO.	A	B	T	WT.Kg/mtr.
2938	110.00	58.00	1.30	1.273

SEC.NO.	A	B	T	WT.Kg/mtr.
2939	110.00	58.00	1.30	2.255

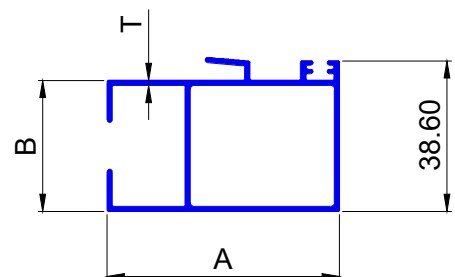
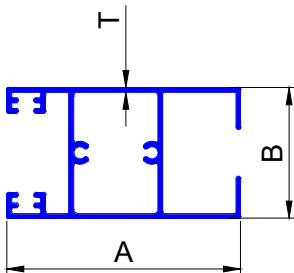

SEC.NO.	A	B	T	WT.Kg/mtr.
2940	60.00	33.50	1.20	0.827

SEC.NO.	A	B	T	WT.Kg/mtr.
2943	59.60	33.60	1.30	0.816

SLIDING WINDOWS

2023-24

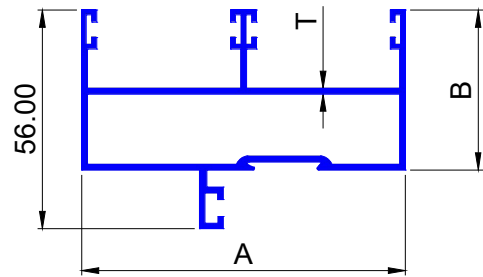
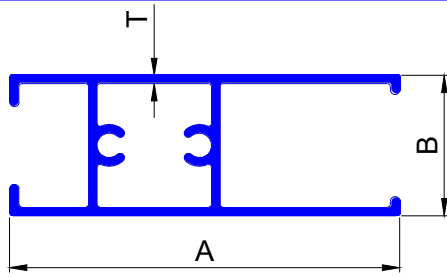

SEC.NO.	A	B	T	WT.Kg/mtr.
2946	50.00	18.00	1.06	0.449

SEC.NO.	A	B	T	WT.Kg/mtr.
2947	83.03	41.00	1.50	1.296

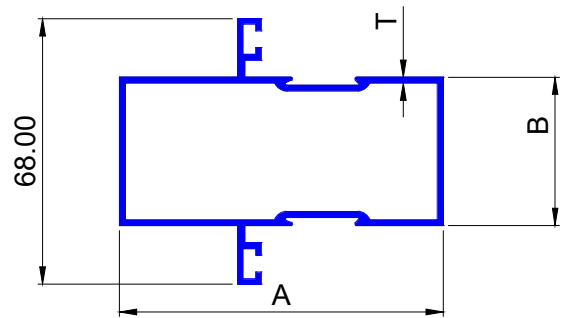
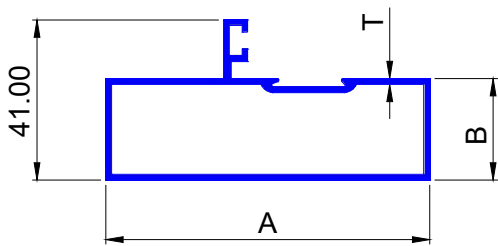

SEC.NO.	A	B	T	WT.Kg/mtr.
2948	83.03	26.00	1.50	0.999

SEC.NO.	A	B	T	WT.Kg/mtr.
2949	83.03	38.00	1.50	1.236

15.0X45.0 MM SLIDING WINDOW

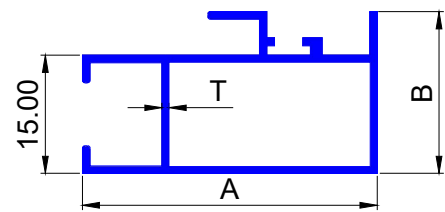
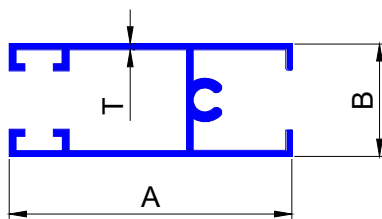

SEC.NO.	A	B	T	WT.Kg/mtr.
2950	37.50	15.00	0.90	0.307
2952	37.50	15.00	1.50	0.440

SEC.NO.	A	B	T	WT.Kg/mtr.
2954	37.50	20.50	0.90	0.315
2955	37.50	20.50	1.10	0.396
2956	37.50	20.50	1.30	0.440

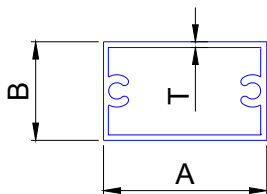

SEC.NO.	A	B	T	WT.Kg/mtr.
2983	42.00	20.00	1.2	0.446

SEC.NO.	A	B	T	WT.Kg/mtr.
---------	---	---	---	------------

ALL DIMENSIONS ARE IN mm.

15.0X45.0 MM SLIDING WINDOWS

2023-24

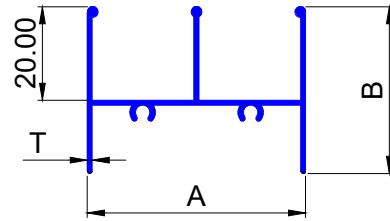
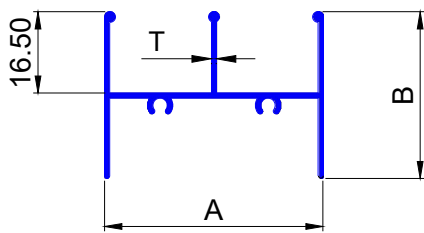

SEC.NO.	A	B	T	WT.Kg/mtr.
2959	44.50	34.00	1.00	0.398

SEC.NO.	A	B	T	WT.Kg/mtr.
2960	45.20	35.00	1.10	0.500

18.0X62.0 MM SLIDING WINDOW

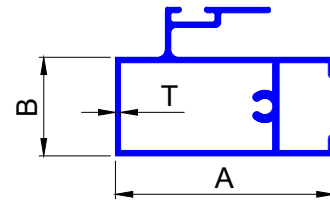
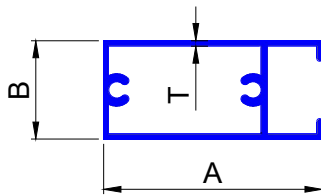

SEC.NO.	A	B	T	WT.Kg/mtr.
2961	40.00	18.00	0.60	0.255
2962	40.00	18.00	0.75	0.300
2963	40.00	18.00	0.90	0.345
2964	40.00	18.00	1.10	0.409
2965	40.00	18.00	1.30	0.465
2966	40.00	18.00	1.50	0.531
2967	50.00	18.00	1.20	0.511

SEC.NO.	A	B	T	WT.Kg/mtr.
2968	40.00	18.00	0.70	0.341
2969	40.00	18.00	0.90	0.402
2970	40.00	18.00	1.00	0.464
2971	40.00	18.00	1.10	0.500
2972	40.00	18.00	1.50	0.582
2973	50.00	18.00	1.00	0.498
2979	40.00	18.00	0.65	0.300

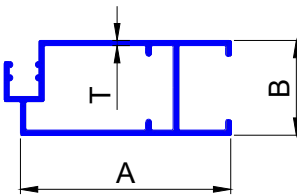
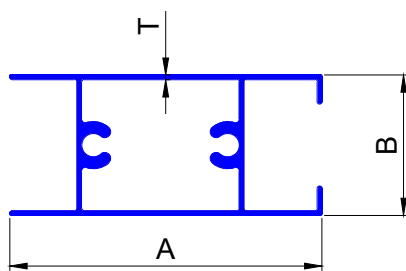

SEC.NO.	A	B	T	WT.Kg/mtr.
2974	40.00	18.00	0.80	0.308
2975	40.00	18.00	0.60	0.255
2976	40.00	18.00	0.95	0.365
2977	40.00	18.00	1.35	0.480
2978	40.00	18.00	1.50	0.531

SEC.NO.	A	B	T	WT.Kg/mtr.
2980	40.00	18.00	1.35	0.474

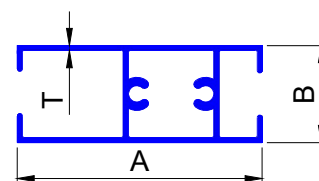

SEC.NO.	A	B	T	WT.Kg/mtr.
2981	51.50	18.00	0.95	0.431
2982	51.50	18.00	1.10	0.491

18.0X62.0 MM SLIDING WINDOWS

2023-24

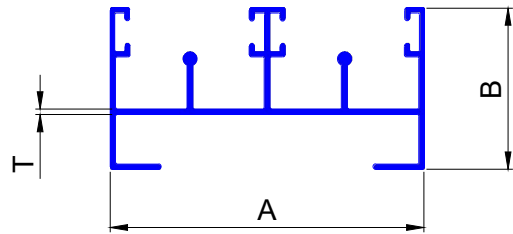
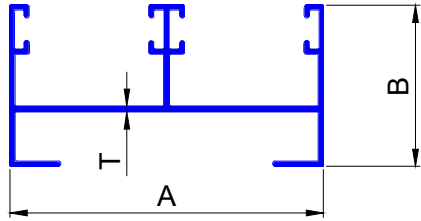

SEC.NO.	A	B	T	WT.Kg/mtr.
2986	61.85	31.75	0.70	0.368
2988	61.85	31.75	1.00	0.519
2989	61.85	31.75	1.10	0.587
2990	61.85	31.75	1.25	0.639
2991	61.85	31.75	1.35	0.684
2984	61.85	31.75	1.55	0.833
92986	61.85	31.75	1.57	0.314

SEC.NO.	A	B	T	WT.Kg/mtr.
2992	61.85	31.75	0.65	0.395
2993	61.85	31.75	0.80	0.486
2994	61.85	31.75	0.95	0.560
2995	61.85	31.75	1.05	0.614
2996	61.85	31.75	1.15	0.661
2997	61.85	31.75	1.35	0.776
92992	61.85	31.75	0.50	0.328

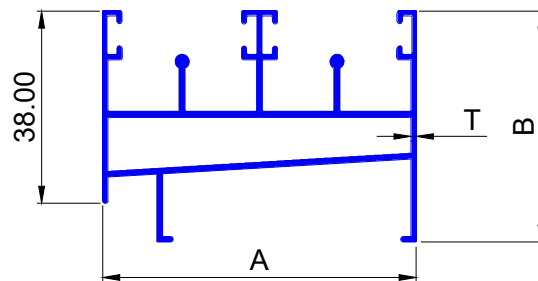

SEC.NO.	A	B	T	WT.Kg/mtr.
2998	62.00	46.00	0.95	0.790
2999	62.00	46.00	1.10	0.905
3000	62.00	46.00	1.20	0.974
3001	62.00	46.00	1.50	1.106

18.0 X 92.0 MM SLIDING WINDOWS

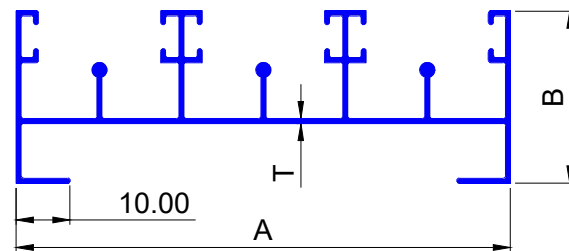
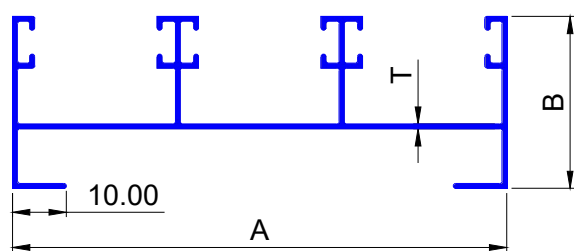

SEC.NO.	A	B	T	WT.Kg/mtr.
3002	92.00	32.00	0.90	0.697
3003	92.00	32.00	1.15	0.786
3004	92.00	32.00	1.25	0.885
3005	92.00	32.00	1.50	1.014

SEC.NO.	A	B	T	WT.Kg/mtr.
3007	92.00	32.00	0.95	0.756
3008	92.00	32.00	1.00	0.827
3009	92.00	32.00	1.25	0.983
3010	92.00	32.00	1.50	1.155

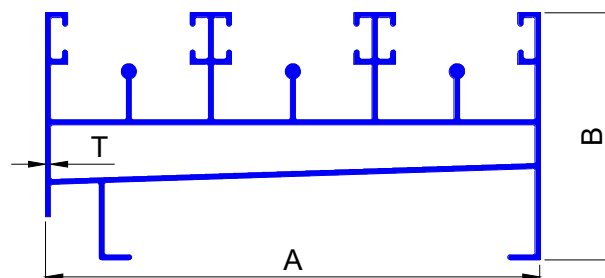
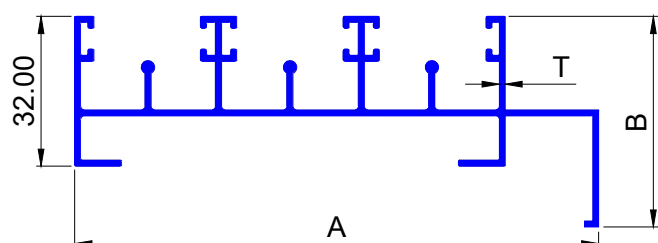

SEC.NO.	A	B	T	WT.Kg/mtr.
3012	112.00	45.00	1.42	1.226

SEC.NO.	A	B	T	WT.Kg/mtr.
3013	92.00	46.00	1.00	1.301

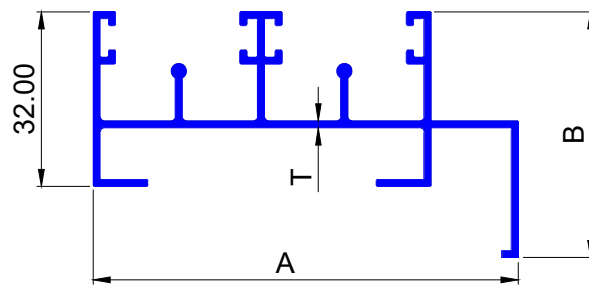
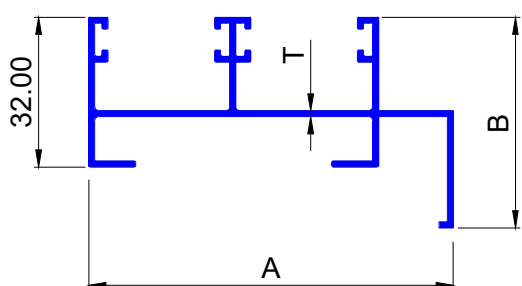

SEC.NO.	A	B	T	WT.Kg/mtr.
3017	77.88	45.00	1.25	0.804

SEC.NO.	A	B	T	WT.Kg/mtr.
3018	77.88	45.00	1.25	0.891

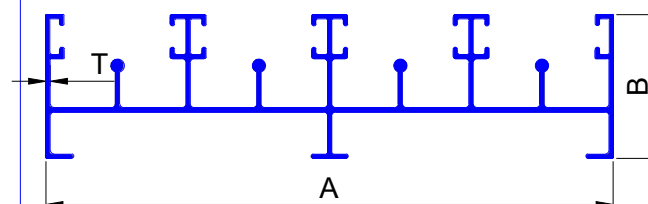
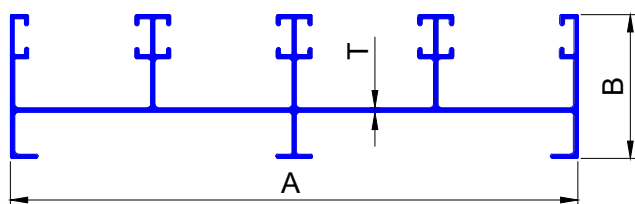

SEC.NO.	A	B	T	WT.Kg/mtr.
3015	122.00	31.00	0.90	0.850

SEC.NO.	A	B	T	WT.Kg/mtr.
3020	122.00	31.00	0.90	0.988

18.0 X 92.0 MM SLIDING WINDOWS

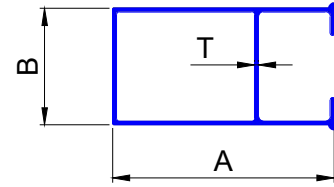
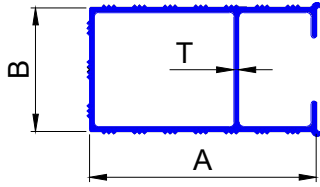

SEC.NO.	A	B	T	WT.Kg/mtr.
3024	38.00	20.00	0.85	0.304

SEC.NO.	A	B	T	WT.Kg/mtr.
3025	38.00	20.00	0.85	0.283
3027	38.00	20.00	1.50	0.486
3028	38.00	20.00	0.65	0.250

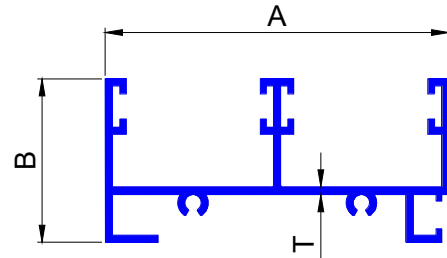
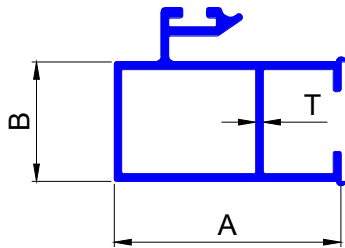

SEC.NO.	A	B	T	WT.Kg/mtr.
3031	38.00	20.00	1.80	0.655

SEC.NO.	A	B	T	WT.Kg/mtr.
3041	62.00	29.50	1.35	0.710
3042	62.00	29.50	1.50	0.806

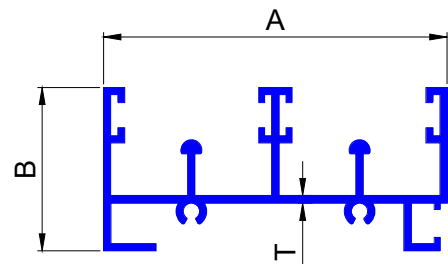
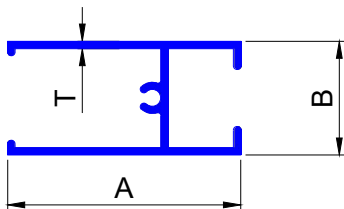

SEC.NO.	A	B	T	WT.Kg/mtr.
3033	41.00	20.00	1.30	0.405
3034	41.00	20.00	1.50	0.464

SEC.NO.	A	B	T	WT.Kg/mtr.
3044	62.00	29.50	1.35	0.805
3045	62.00	29.50	1.50	0.887

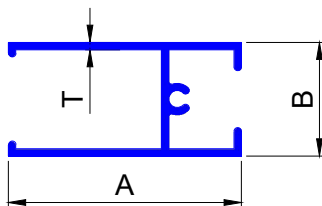

SEC.NO.	A	B	T	WT.Kg/mtr.
3037	41.00	20.00	1.50	0.464
3095	60.00	29.00	1.20	0.578

20.0 X 92.0 MM SLIDING WINDOWS

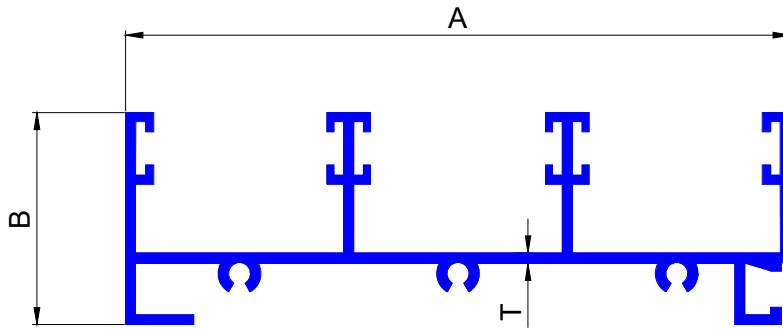

SEC.NO.	A	B	T	WT.Kg/mtr.
3048	92.36	29.70	1.55	1.033

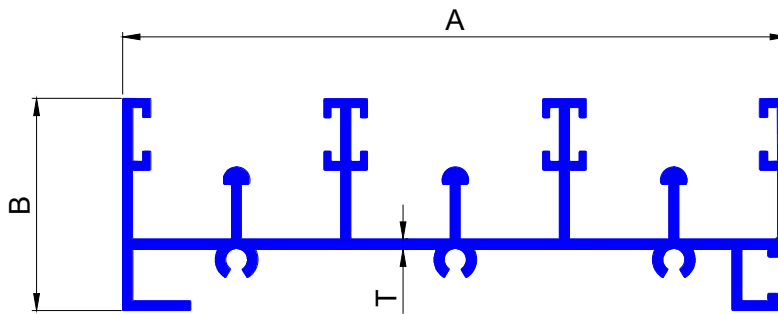

SEC.NO.	A	B	T	WT.Kg/mtr.
3050	92.36	29.70	1.60	1.257

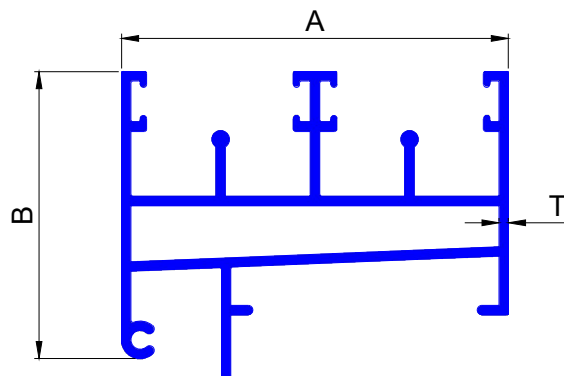

SEC.NO.	A	B	T	WT.Kg/mtr.
3052	62.00	46.00	1.50	1.232

25.40 X 75.0 MM SLIDING WINDOWS

2023-24

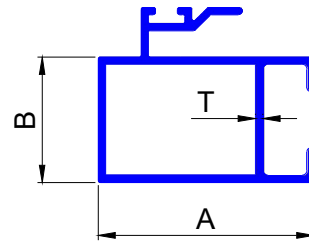
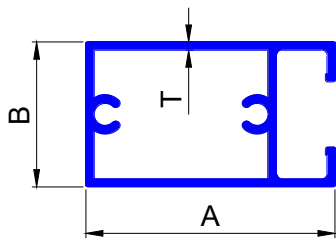

SEC.NO.	A	B	T	WT.Kg/mtr.
3061	43.00	25.00	1.45	0.631

SEC.NO.	A	B	T	WT.Kg/mtr.
3066	43.00	25.00	1.50	0.714
3067	43.00	25.00	1.80	0.778

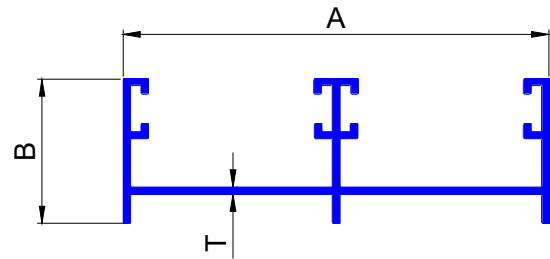
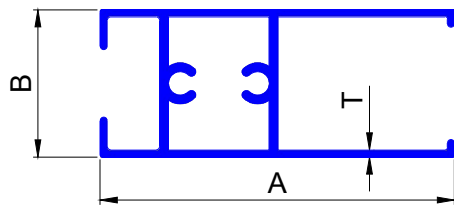

SEC.NO.	A	B	T	WT.Kg/mtr.
3070	60.00	25.00	1.20	0.675
3071	60.00	25.00	1.50	0.765
3072	60.00	29.00	1.60	0.895

SEC.NO.	A	B	T	WT.Kg/mtr.
3082	75.00	25.40	1.35	0.672
3083	75.00	25.40	1.50	0.819

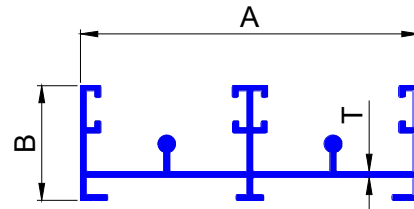
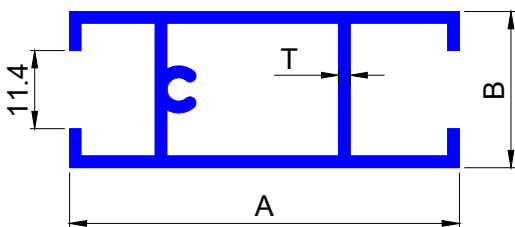

SEC.NO.	A	B	T	WT.Kg/mtr.
3073	50.00	20.00	1.50	0.630

SEC.NO.	A	B	T	WT.Kg/mtr.
3086	75.00	25.40	1.30	0.821
3087	75.00	25.40	1.50	0.928

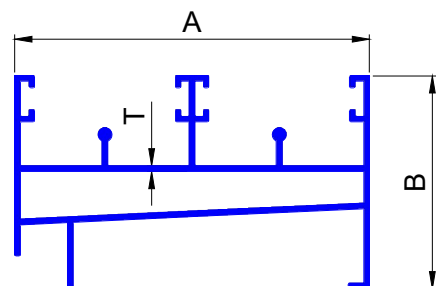
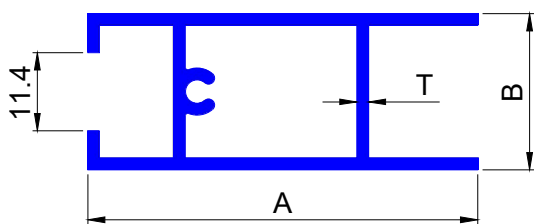

SEC.NO.	A	B	T	WT.Kg/mtr.
3074	50.00	20.00	1.50	0.606

SEC.NO.	A	B	T	WT.Kg/mtr.
3088	75.00	45.00	1.20	1.034

ALL DIMENSIONS ARE IN mm.

SLIDING WINDOW

2023-24

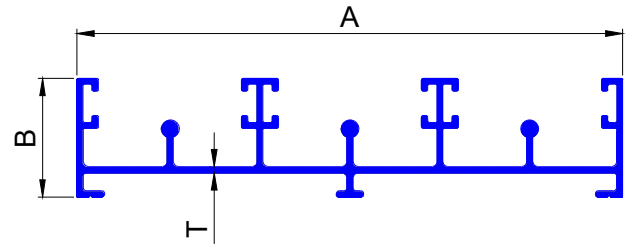
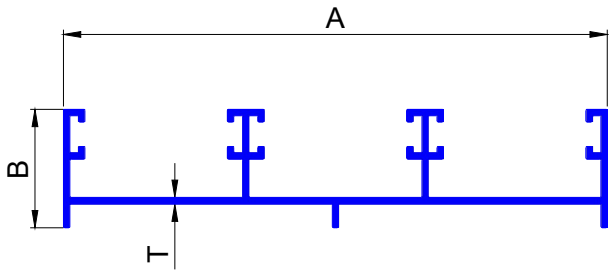

SEC.NO.	A	B	T	WT.Kg/mtr.
3090	116.20	25.40	1.40	1.040
3091	116.20	25.40	1.60	1.147

SEC.NO.	A	B	T	WT.Kg/mtr.
3092	116.20	25.40	1.30	1.146
3093	116.20	25.40	1.60	1.229

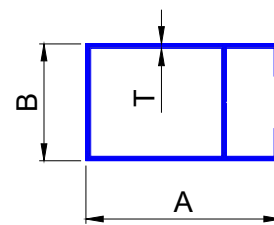
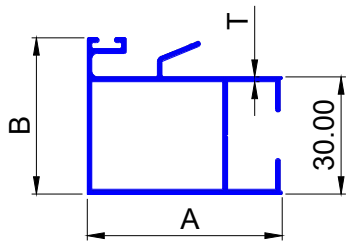

SEC.NO.	A	B	T	WT.Kg/mtr.
3096	50.00	40.00	1.20	0.684

SEC.NO.	A	B	T	WT.Kg/mtr.
3097	50.00	30.00	1.20	0.550

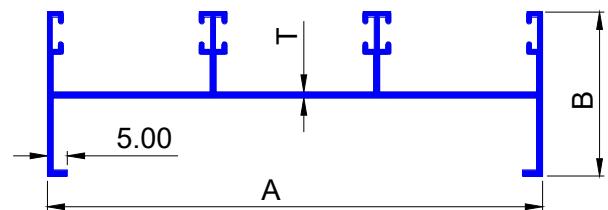
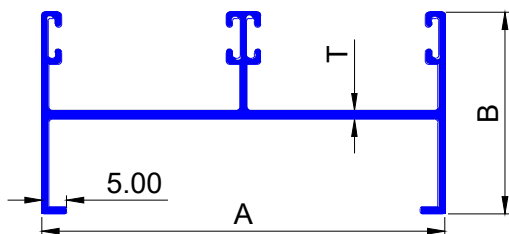

SEC.NO.	A	B	T	WT.Kg/mtr.
3077	82.00	41.00	1.75	0.896

SEC.NO.	A	B	T	WT.Kg/mtr.
3075	124.00	41.00	1.50	1.165
3094	124.00	41.00	1.20	0.990

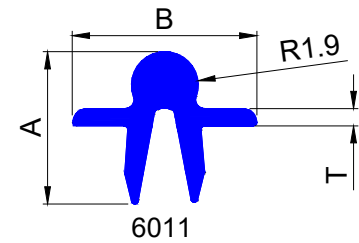
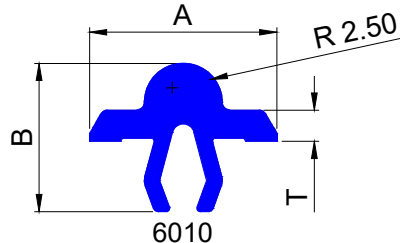
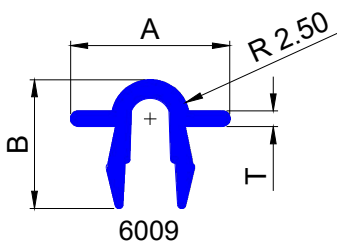

SEC.NO.	A	B	T	WT.Kg/mtr.
6009	10.20	8.25	1.00	0.064
6011	8.60	10.5	1.00	0.076

SEC.NO.	A	B	T	WT.Kg/mtr.
6010	12.00	9.50	2.00	0.114

ALL DIMENSIONS ARE IN mm.

SLIDING WINDOWS

2023-24

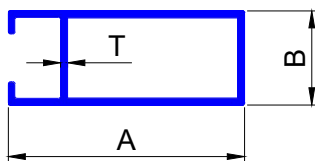

SEC.NO.	A	B	T	WT.Kg/mtr.
3101	50.00	20.00	1.50	0.511

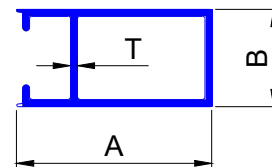

SEC.NO.	A	B	T	WT.Kg/mtr.
3105	39.50	19.50	0.70	0.232

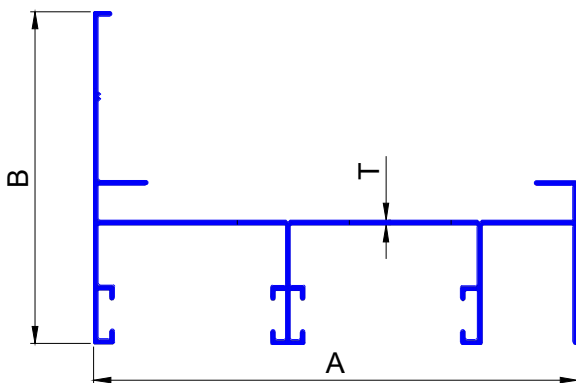

SEC.NO.	A	B	T	WT.Kg/mtr.
3108	80.00	55.00	1.35	0.828

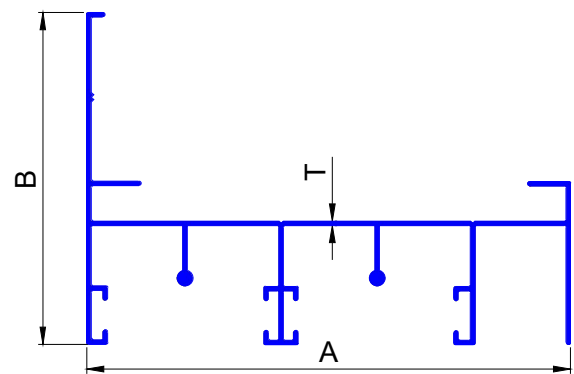

SEC.NO.	A	B	T	WT.Kg/mtr.
3109	80.00	55.00	1.20	0.868

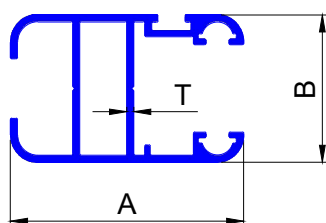

SEC.NO.	A	B	T	WT.Kg/mtr.
3110	42.80	27.00	1.30	0.641

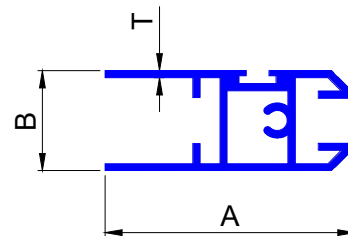

SEC.NO.	A	B	T	WT.Kg/mtr.
3111	50.00	20.00	1.40	0.676

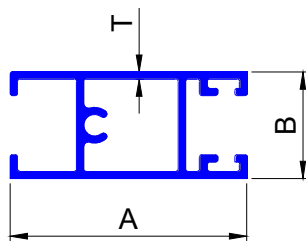

SEC.NO.	A	B	T	WT.Kg/mtr.
3114	40.00	18.00	1.20	0.460

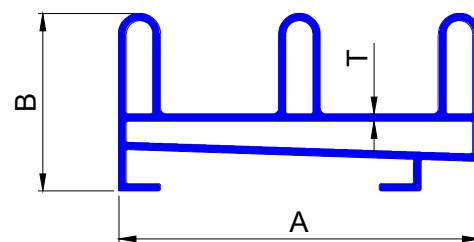

SEC.NO.	A	B	T	WT.Kg/mtr.
3115	61.00	30.00	1.20	0.856

SLIDING WINDOWS

2023-24

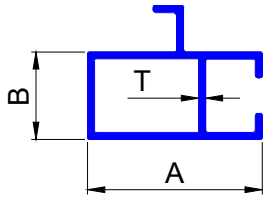

SEC.NO.	A	B	T	WT.Kg/mtr.
3117	40.00	20.00	1.60	0.591

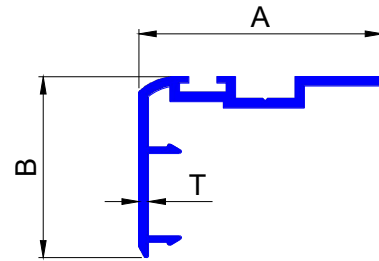

SEC.NO.	A	B	T	WT.Kg/mtr.
3119	39.00	29.00	1.50	0.338
3118 NEW	39.00	29.00	0.90	0.218

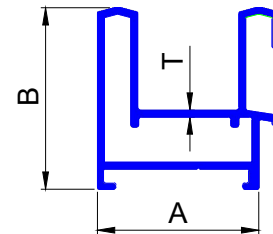
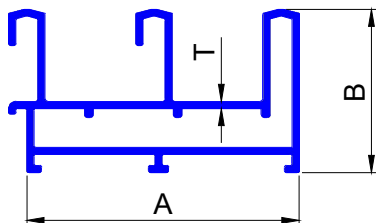

	A	SEC.NO.	B	T	WT.Kg/mtr.
3120	75.00	45.00	1.50	1.397	
6760	75.00	45.00	1.30	1.257	
8602	75.00	45.00	1.20	1.201	

SEC.NO.	A	B	T	WT.Kg/mtr.
3121	40.00	45.00	1.50	0.902
3121new	40.00	45.00	1.10	0.628

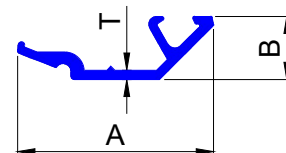
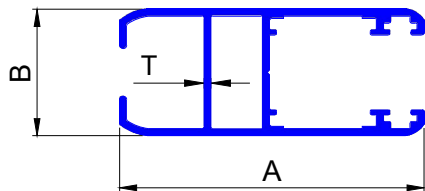

SEC.NO.	A	B	T	WT.Kg/mtr.
3122	65.00	27.00	1.50	0.889
3122 new	65.00	27.00	0.85	0.889

SEC.NO.	A	B	T	WT.Kg/mtr.
3123	25.40	8.25	1.20	0.120

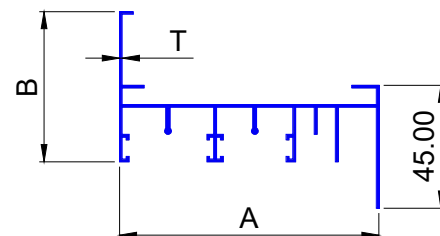
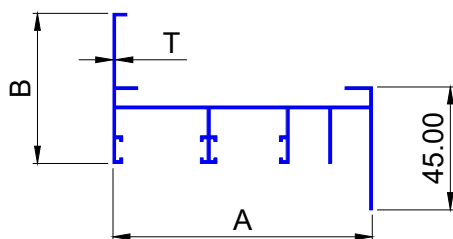

SEC.NO.	A	B	T	WT.Kg/mtr.
3124	95.00	55.00	1.00	0.815

SEC.NO.	A	B	T	WT.Kg/mtr.
3125	95.00	55.00	1.00	0.931

SLIDING WINDOWS

2023-24

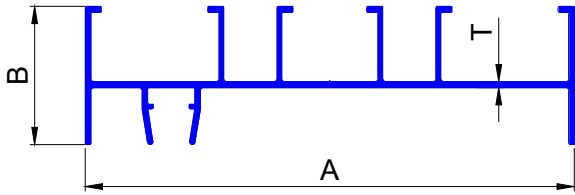

SEC.NO.	A	B	T	WT.Kg/mtr.
3126	129.20	36.50	1.60	1.327

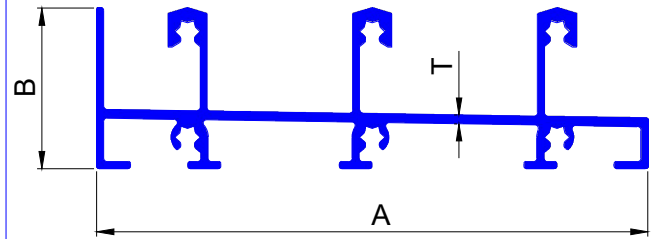

SEC.NO.	A	B	T	WT.Kg/mtr.
3127	126.00	36.50	2.00	2.150

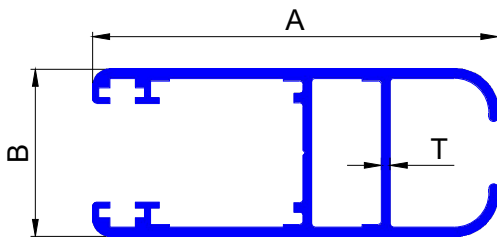

SEC.NO.	A	B	T	WT.Kg/mtr.
3130	65.00	26.80	1.50	0.840

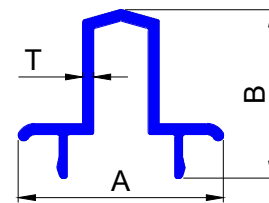

SEC.NO.	A	B	T	WT.Kg/mtr.
3134	26.30	21.60	1.40	0.234

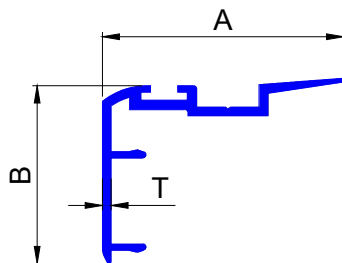

SEC.NO.	A	B	T	WT.Kg/mtr.
3135	38.70	28.50	1.40	0.307

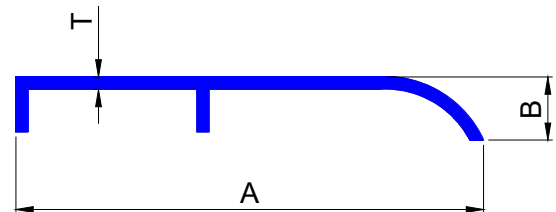

SEC.NO.	A	B	T	WT.Kg/mtr.
3147	59.96	8.10	1.60	0.314

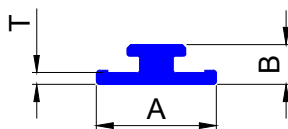

SEC.NO.	A	B	T	WT.Kg/mtr.
3153	15.40	5.10	1.50	0.120

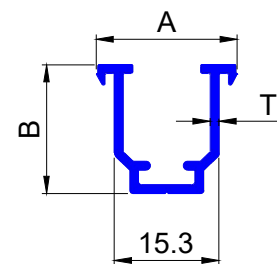

SEC.NO.	A	B	T	WT.Kg/mtr.
3156	24.10	22.00	1.50	0.289

SLIDING WINDOWS

2023-24

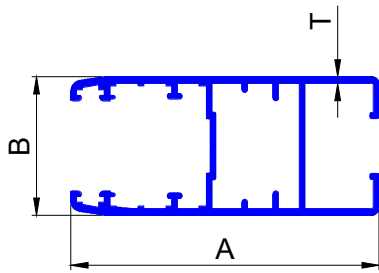

SEC.NO.	A	B	T	WT.Kg/mtr.
3159	82.30	37.00	1.80	1.390

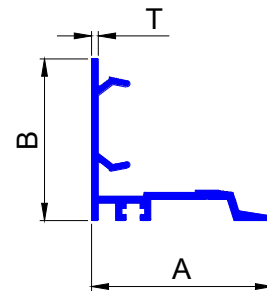

SEC.NO.	A	B	T	WT.Kg/mtr.
3161	38.70	34.50	1.50	0.405

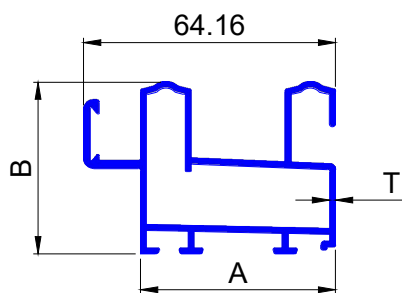

SEC.NO.	A	B	T	WT.Kg/mtr.
3164	50.00	44.00	1.50	1.151

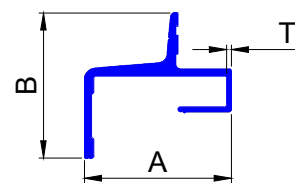

SEC.NO.	A	B	T	WT.Kg/mtr.
3166	31.40	31.00	1.50	0.350

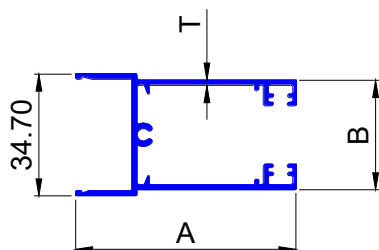

SEC.NO.	A	B	T	WT.Kg/mtr.
3188	62.81	31.20	1.50	0.791

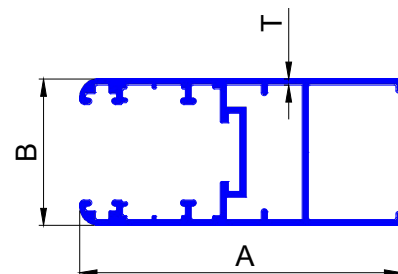

SEC.NO.	A	B	T	WT.Kg/mtr.
6657	82.55	37.50	1.50	1.267

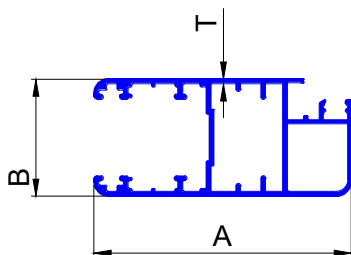

SEC.NO.	A	B	T	WT.Kg/mtr.
7495	82.50	37.50	1.50	1.376

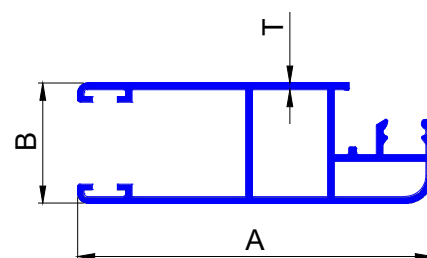

SEC.NO.	A	B	T	WT.Kg/mtr.
7828	65.00	22.00	1.20	0.669

ALL DIMENSIONS ARE IN mm.

SLIDING WINDOWS

2023-24

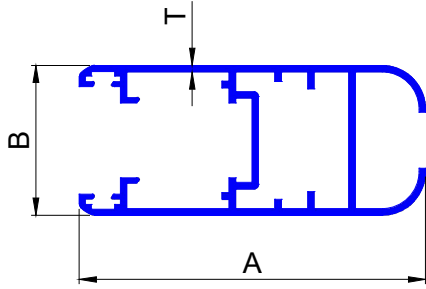

SEC.NO.	A	B	T	WT.Kg/mtr.
8636	73.95	32.00	1.40	1.013

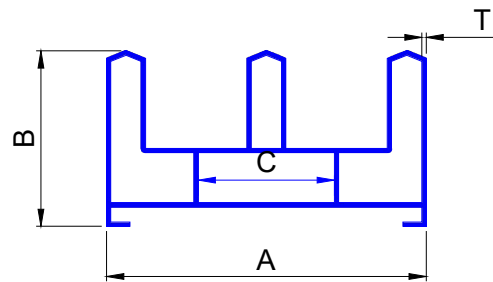

SEC.NO.	A	B	C	T	WT.Kg/mtr.
3139	82.00	45.00	35.00	1.10	1.153

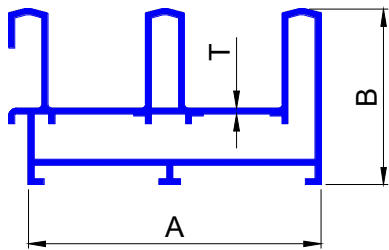

SEC.NO.	A	B	T	WT.Kg/mtr.
8664	75.00	45.00	1.50	1.473
3140	75.00	45.00	1.30	1.294

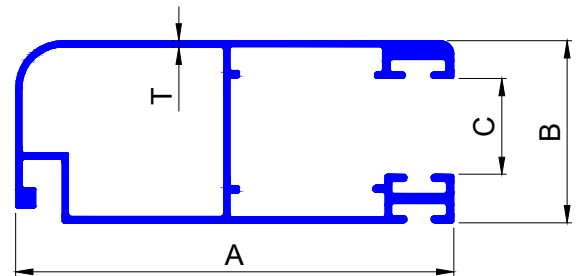

SEC.NO.	A	B	C	T	WT.Kg/mtr.
3141	82.00	27.00	14.20	0.95	0.653

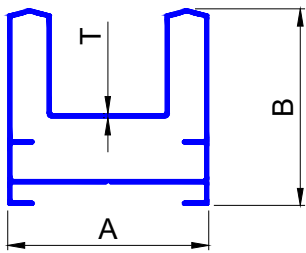

SEC.NO.	A	B	T	WT.Kg/mtr.
3142	46.00	45.00	0.96	0.628

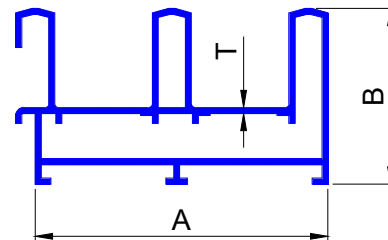

SEC.NO.	A	B	T	WT.Kg/mtr.
3143	75.00	45.00	1.00	1.100

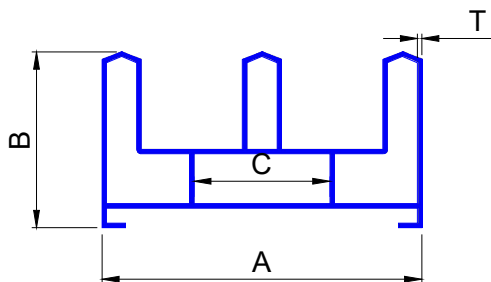

SEC.NO.	A	B	T	C	WT.Kg/mtr.
3144	82.00	45.00	1.50	50.8	1.518

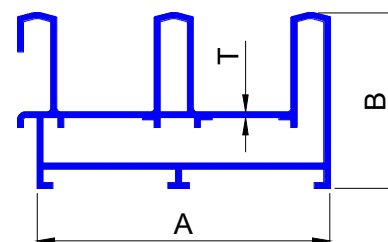

SEC.NO.	A	B	T	WT.Kg/mtr.
3145	75.00	45.00	1.50	1.490

ALL DIMENSIONS ARE IN mm.

SLIDING WINDOWS

2023-24

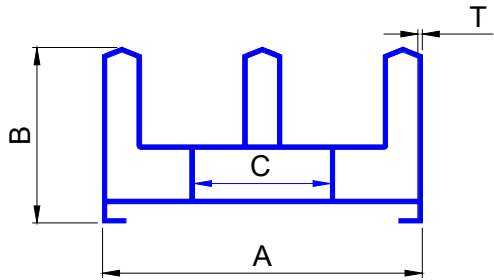

SEC.NO.	A	B	C	T	WT.Kg/mtr.	SEC.NO.	A	B	C	T	WT.Kg/mtr.
3146	82.00	45.00	50.80	0.90	1.020						

22MM DOMAL SECTIONS

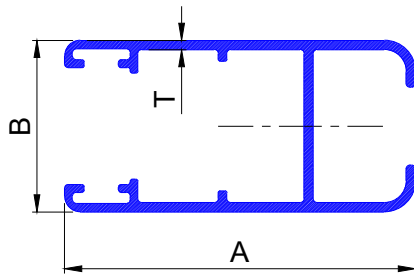

SEC.NO.	A	B	T	WT.Kg/mtr.
71401	45.00	22.00	1.20	0.423

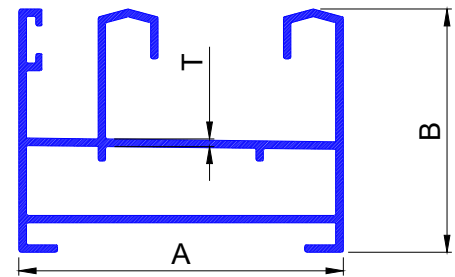

SEC.NO.	A	B	T	WT.Kg/mtr.
71402	52.00	39.00	1.20	0.789

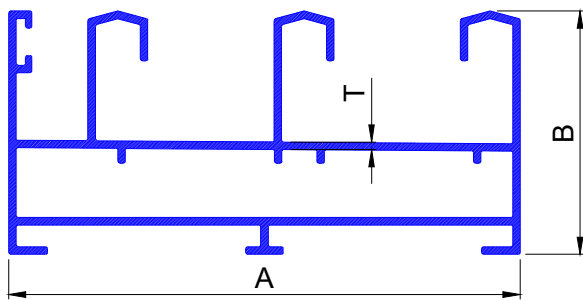

SEC.NO.	A	B	T	WT.Kg/mtr.
71403	82.00	39.00	1.20	1.148

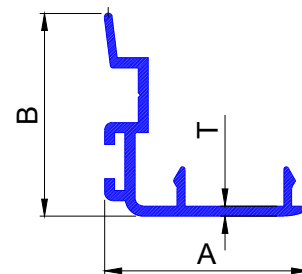

SEC.NO.	A	B	T	WT.Kg/mtr.
71404	26.17	26.00	1.30	0.234

SEC.NO.	A	B	T	WT.Kg/mtr.

SEC.NO.	A	B	T	WT.Kg/mtr.